

**AMATEUR RADIO EMERGENCY SERVICE**  
**ARES FIELD RESOURCES MANUAL**

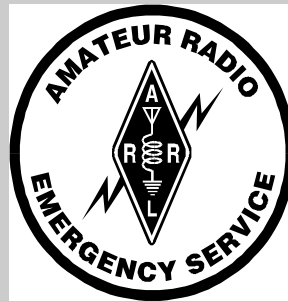

**A QUICK TRAINER AND FIELD RESOURCE GUIDE  
FOR THE EMERGENCY COMMUNICATOR**

**PUBLISHED BY THE AMERICAN RADIO RELAY LEAGUE**

# ARES FIELD RESOURCES MANUAL

This manual is intended to serve as a quick trainer and reference for amateurs deployed in the field for emergency services work, primarily through the Amateur Radio Emergency Service (ARES). It provides basic program information, forms, operating aids, and templates to be customized for the local area to include reference information such as important phone numbers, emergency frequencies, maps, organizational details, and so forth.

This work is based on the *Amateur Radio Emergency Communications Manual*, an excellent effort by Darlene LaMont, KD6GCK. It is also based on several other existing efforts, most notably the Alameda County *Instant Trainer* edited by David Hunt, KB6JAW and Syd Furman, W6QWK, and the Santa Clara Section *Net Control Manual*. Thanks go to Maryland/DC Section Emergency Coordinator Mike Carr, WA1QAA, and Assistant SM Al Nollmeyer, W3YVQ, for their expertise and invaluable assistance. Thanks to David W. Hansen, N7AUA, for tips on “ready” kits, and William Wornham, NZ1D, Emergency Management Director, and ARRL Emergency Coordinator, for his treatise on hazardous materials incidents. And finally, thanks go to the members of the League’s Public Service Advisory Committee, and its chairman, Steve Wilson, KA6S, for their valuable input. 73,

Rick Palm, K1CE  
Field Services Manager  
Newington, Connecticut  
December, 1995

# TABLE OF CONTENTS

Topic	Page	Topic	Page
FIRST THINGS FIRST	4	APPENDICES:	61
CHECKLISTS	6	1. FCC Rules	62
BASIC PROGRAM INFORMATION	11	2. Third Party Countries List	66
• ARES	12	3. Standard Power Connector	68
• NTS	15	4. Section Emergency Coordinators	69
• RACES	19	5. Section Emergency Nets	75
• ICS	21	6. Wide Area Emergency Nets	79
HAZARDOUS MATERIALS	22	7. ARESMAT Concept	80
OPERATING PRINCIPLES	26	8. Federal Response Plan	83
MESSAGE FORMATS	30	9. National Disaster Medical System	85
LOCAL NETS/CONTACTS	38	10. Wilderness Protocol	87
SECTION ARES MAP	49		
EMERGENCY PLAN	50	• ARES Registration Form	88
OPERATING AIDS	51	• Incident Report Forms	89

HURRICANE INFORMATION	58	• Incident Log Sheets	93
-----------------------	----	-----------------------	----

# FIRST THINGS FIRST

Topic	Page
WHAT TO DO <i>FIRST</i> IN CASE OF EMERGENCY	5
INITIAL ACTION CHECKLIST	6

## **WHAT TO DO *FIRST* IN CASE OF AN EMERGENCY**

- 1. CHECK THAT YOU AND YOUR FAMILY ARE SAFE AND SECURE BEFORE YOU RESPOND AS AN ARES VOLUNTEER.**
- 2. CHECK THAT YOUR PROPERTY IS SAFE AND SECURE BEFORE YOU RESPOND AS AN ARES VOLUNTEER.**
- 3. MONITOR \_\_\_\_\_ (PUT YOUR ASSIGNED LOCAL ARES EMERGENCY NET FREQUENCY HERE).**
- 4. FOLLOW THE INSTRUCTIONS YOU RECEIVE FROM THE ARES OFFICIALS IN CHARGE ON THE ABOVE FREQUENCY.**
- 5. CONTACT YOUR LOCAL EMERGENCY COORDINATOR, OR HIS/HER DESIGNEE, FOR FURTHER INSTRUCTIONS.**

## INITIAL ACTION CHECKLIST

The net control station and/or ARES officials on the designated emergency net will provide additional instructions, including information on frequencies used for other resource and tactical nets. Normally, a resource net will enroll volunteers and provide information on how you can assist.

- **Be prepared to operate. Check all equipment and connections.**
- **Check-in with your assigned contact. Deploy to assignment with “Ready” kit.**
- **Obtain tactical call sign for your location/assignment.**
- **Initiate personal event log (use form at end of this booklet).**
- **Enter assigned frequency(s) on log sheet and on emergency/frequency plan.**
- **Use log form to record messages handled.**
- **Use a formal message form when a precise record is required.**
- **Use tactical call sign for your location, while observing FCC’s ten-minute i-d rule.**
- **Monitor your assigned frequency AT ALL TIMES. Notify NCS if you have to leave.**

# EQUIPMENT AND PERSONAL CHECKLISTS

<b>Topic</b>	<b>Page</b>
<b>BASIC DEPLOYMENT EQUIPMENT CHECKLIST</b>	<b>8</b>
<b>EXTENDED DEPLOYMENT EQUIPMENT CHECKLIST</b>	<b>9</b>
<b>ABOUT YOUR “READY” KIT</b>	<b>10</b>

## **BASIC DEPLOYMENT EQUIPMENT CHECKLIST**

When responding to an emergency event, or even a training exercise, there is a minimum set of equipment and personal gear you should bring with you to get the job done. Basic items include:

- **2-METER HT**
- **2-METER MAGMOUNT ANTENNA AND COAX**
- **EAR-PHONE**
- **PAPER AND PENCIL**
- **ARES ID CARD**
- **EXTRA BATTERIES**
- **APPROPRIATE CLOTHING**
- **FOOD AND WATER**

The majority of these items should be kept in a "Ready Kit." Just pick it up on your way out the door for deployment. You might also consider the items on the following list for inclusion in this ready kit, designed to allow you to stay in the field for up to 72 hours.



## EXTENDED (72-HOUR) DEPLOYMENT EQUIPMENT CHECKLIST

- Snacks
- Throat lozenges
- Prescriptions
- First aid kit
- Log books
- 3 day change of clothes
- 3 day supply of water and food
- Flashlight
- Candles
- Alarm clock
- Electrical and Duct tape
- Safety glasses
- Additional Radios, packet gear
- Headphones
- RF Connectors
- Patch cords
- Extra coax
- Liquid refreshments
- Aspirin
- Toilet articles
- Message forms
- Shelter (tent and sleeping bag)
- Foul weather gear
- Portable stove; Mess kit with cleaning kit
- Batteries
- Water proof matches
- Toolbox
- Soldering iron and solder
- VOM
- Microphones
- Power supplies, chargers
- Antennas with mounts
- SWR bridge (VHF and HF).
- ARRL Standardized Connectors (Molex 1545)

## ABOUT YOUR “READY” KIT

**Power** -- Your radio 72-hour kit should have several sources of power in it, with extra battery packs and an alkaline battery pack for your HT. For mobile VHF and UHF radios, larger batteries are needed. Gel-cell or deep-cycle marine batteries would be good sources of battery power, and you must keep them charged and ready to go. It is also wise to have alternate means available to charge your batteries during the emergency. You can charge smaller batteries from other larger batteries. You can build a solar charging device. If you're lucky, you may have access to a power generator that can be used in place of the normal electrical lines. Have more battery capacity than you think you might need. Have several methods available to connect your radios to different power sources.

**Gain Antennas** -- You can expect to need some kind of gain antenna for your HT, as well as an additional gain antenna that can be used on either your HT or your mobile rig. The extra antenna might be needed by someone else, or your first antenna might break. For VHF and UHF, you can build a J-pole from a TV twinlead, for an inexpensive and very compact antenna. Have several lengths of coax in your kit, totaling at least 50 feet and with barrel connectors to connect them together.

**Personal** -- Include staples: water, or a reliable water filtration and purification system; enough food for three days; eating utensils, a drinking cup and, if needed, a means of cooking your food. Shelter is also important. Here, you are only limited by the size of your kit and the thickness of your wallet. Some hams plan to use their RVs as shelter, conditions permitting. Other disaster conditions may make the use of an RV impossible, so you should have several different plans for shelter. Light is important psychologically during an emergency. Make sure that you have several light sources available. Various battery-powered lights are available, and propane or gasoline-fueled lanterns are also good possibilities.

# BASIC EMERGENCY PROGRAM INFORMATION

<b>Topic</b>	<b>Page</b>
<b>AMATEUR RADIO EMERGENCY SERVICE</b>	<b>12</b>
<b>ARES/NTS ORGANIZATION CHART</b>	<b>14</b>
<b>NATIONAL TRAFFIC SYSTEM</b>	<b>15</b>
<b>EMERGENCY ALERTING CHART</b>	<b>17</b>
<b>TYPES OF EMERGENCY NETS</b>	<b>18</b>
<b>RADIO AMATEUR CIVIL EMERGENCY SERVICE</b>	<b>19</b>
<b>INCIDENT COMMAND SYSTEM</b>	<b>21</b>

## **AMATEUR RADIO EMERGENCY SERVICE (ARES)**

The Amateur Radio Emergency Service (ARES) consists of licensed amateurs who have voluntarily registered their qualifications and equipment for communications duty in the public interest when disaster strikes. Every licensed amateur, regardless of membership in ARRL or any other local or national organization, is eligible for membership in the ARES. The only qualification, other than possession of an Amateur Radio license, is a sincere desire to serve. Because ARES is an amateur service, only amateurs are eligible for membership. The possession of emergency-powered equipment is desirable, but is not a requirement for membership.

### **ARES Organization**

There are three levels of ARES organization--section, district and local. At the section level, the Section Emergency Coordinator is appointed by the Section Manager (who is elected by the ARRL members in his section) and works under his supervision. In most sections, the SM delegates to the SEC the administration of the section emergency plan and the authority to appoint district and local ECs.

It is at the local level where most of the organization and operation is effected, because this is the level at which most emergencies occur and the level at which ARES leadership makes direct contact with the ARES member-volunteers and with officials of the agencies to be served. The local EC is therefore the key contact in the ARES. The EC is appointed by the SEC, usually on the recommendation of the district EC (DEC). Depending on how the SEC has set up the section for

administrative purposes, the EC may have jurisdiction over a small community or a large city, an entire county or even a group of counties. Whatever jurisdiction is assigned, the EC is in charge of all ARES activities in his area, not just one interest group, one agency, one club or one band.

In large sections, the SECs have the option of grouping their EC jurisdictions into "districts" and appointing a district EC to coordinate the activities of the local ECs. In some cases, the districts may conform to the boundaries of governmental planning or emergency-operations districts, while in others they are simply based on repeater coverage or geographical boundaries.

Special-interest groups are headed up by "assistant emergency coordinators," designated by the EC to supervise activities of groups operating in certain bands, especially those groups which play an important role at the local level, but they may be designated in any manner the EC deems appropriate. These assistants, with the EC as chairman, constitute the local ARES "planning committee" and they meet together to discuss problems and plan projects to keep the ARES group active and well-trained.

There are any number of different situations and circumstances that might confront an EC, and his ARES unit should be organized in anticipation of them. There is no specific point at which organization ceases and operation commences. Both phases must be concurrent because a living organization is a changing one, and the operations of a changing organization must change with the organization.



## NATIONAL TRAFFIC SYSTEM (NTS)

The National Traffic System is designed to meet two principal objectives: rapid movement of traffic from origin to destination, and training amateur operators to handle written traffic and participate in directed nets. NTS operates daily, and consists of four different net levels--Area, Region, Section, and Local--which operate in an orderly time sequence to effect a definite flow pattern for traffic from origin to destination.

### **Local Nets**

Local nets are those which cover small areas such as a community, city, county or metropolitan area, not a complete ARRL section. They usually operate at VHF (typically 2-meter FM) at times and on days most convenient to their members. Some are designated as emergency (ARES) nets that do not specialize in traffic handling. Local nets are intended mainly for local delivery of traffic. Some NTS local nets operate on a daily basis, just as do other nets of the system, to provide outlets for locally-originated traffic and to route the incoming traffic as closely as possible to its actual destination before delivery--a matter of practice in a procedure that might be required in an emergency. Most local nets and even some section nets in smaller sections are using repeaters to excellent effect. Average coverage on VHF can be extended tenfold or more using a strategically located repeater, and this can achieve a local coverage area wide enough to encompass many of the smaller sections.

## **Section Nets**

Coverage of the section may be accomplished either by individual stations reporting in, by representatives of NTS local nets or both. The section may have more than one net (a CW net, a VHF net and an SSB net, for examples). Section nets are administered by an appointed Section Traffic Manager or designated Net Managers. The purpose of the section net is to handle intra-section traffic, distribute traffic coming down from higher NTS echelons, and put inter-section traffic in the hands of the amateur designated to report into the next-higher NTS (region) echelon. Therefore, the maximum obtainable participation from section amateurs is desirable.

## **Operation During Disasters**

When a disaster situation arises, NTS is capable of expanding its cyclic operation into complete or partial operation as needed. ECs in disaster areas determine the communications needs and make decisions regarding the disposition of local communications facilities, in coordination with agencies to be served. The SEC, after conferring with the affected DECs and ECs, makes his recommendations to the Section Traffic Manager and/or NTS net managers at section and/or region levels. The decision and resulting action to alert the NTS region management may be performed by any combination of these officials, depending upon the urgency of the situation. While the EC is, in effect, the manager of ARES nets operating at local levels, and therefore makes decisions regarding their activation, managers of NTS nets at local, section, region and area levels are directly responsible for activation of their nets in a disaster situation, at the behest of and on the recommendation of ARES or NTS officials at lower levels.



# NTS EMERGENCY ALERTING CHART

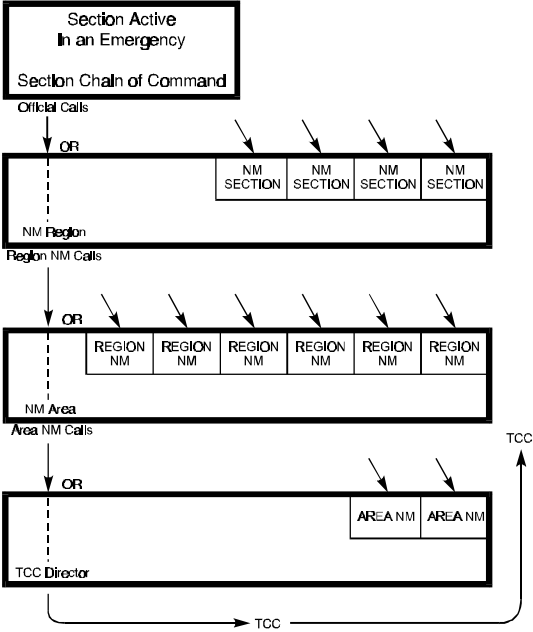

## TYPES OF EMERGENCY NETS

**Tactical Net** -- The Tactical Net is the front line net employed during an incident, usually used by a single government agency to coordinate with Amateur Radio operations within their jurisdiction. There may be several tactical nets in operation for a single incident depending on the volume of traffic and number of agencies involved. Communications include traffic handling, and resource recruiting.

**Resource Net** -- For larger-scale incidents, a Resource Net is used to recruit operators and equipment in support of operations on the Tactical Nets. As an incident requires more operators or equipment, the Resource Net evolves as a check-in place for volunteers to register and receive assignments.

**Command Net** -- As the size of an incident increases and more jurisdictions become involved in the incident, a Command Net may become necessary. This net allows the incident managers to communicate with each other to resolve inter- or intra-agency problems, particularly between cities, or within larger jurisdictional areas. It is conceivable that this net could become cluttered with a high volume of traffic. It may also be necessary to create multiple command nets to promote efficiency.

**Open and Closed Nets** -- A net may operate as an Open or "free form" net, or as a closed net where a net control station is used to control the flow of transmissions on the channel. Typically, when the amount of traffic is low or sporadic a net control isn't required, and an Open net is used. Stations merely listen before they transmit. When a net is declared a "closed" net, then all transmissions must be directed by the NCS.

## **RADIO AMATEUR CIVIL EMERGENCY SERVICE (RACES)**

RACES, administered by local/county/state Emergency Management agencies, with guidance from the Federal Emergency Management Agency (FEMA), is a part of the Amateur Radio Service that provides radio communications for civil-preparedness purposes only, during periods of local, regional or national civil emergencies. These emergencies are not limited to war-related activities, but can include natural disasters such as fires, floods and earthquakes.

### **Operating Procedure**

Amateurs operating in a local RACES organization must be officially enrolled in the local civil-preparedness group. RACES operation is conducted by amateurs using their own primary station licenses, and by existing RACES stations. The FCC no longer issues new RACES (WC prefix) station call signs. Operator privileges in RACES are dependent upon, and identical to, those for the class of license held in the Amateur Radio Service. All of the authorized frequencies and emissions allocated to the Amateur Radio Service are also available to RACES on a shared basis. But in the event that the President invokes his War Emergency Powers, amateurs involved with RACES could be limited to certain specific frequencies (while all other amateur operation would be silenced).

While RACES was originally based on potential use for wartime, it has evolved over the years, as has the meaning of civil defense (which is also called civil preparedness), to encompass all types of emergencies.

While operating in a RACES capacity, RACES stations and amateurs registered in the local RACES organization may not communicate with amateurs not operating in a RACES capacity. (Of course, such restrictions do not apply when such stations are operating in a non-RACES--such as ARES--amateur capacity.) Only civil-preparedness communications can be transmitted (as defined in the FCC Rules). Test and drills are permitted only for a maximum of one hour per week. All test and drill messages must be clearly identified as such.

### **ARES and RACES**

Although RACES and ARES are separate entities, the ARRL advocates dual membership and cooperative efforts between both groups whenever possible. An ARES group whose members are all enrolled in and certified by RACES operate in an emergency with great flexibility. Using the same operators and the same frequencies, an ARES group also enrolled as RACES can "switch hats" from ARES to RACES and RACES to ARES to meet the requirements of the situation as it develops. For example, during a "nondeclared emergency," ARES can operate under ARES, but when an emergency or disaster is officially declared by government emergency management authority, the operation can become RACES with no change in personnel or frequencies.

## INCIDENT COMMAND SYSTEM (ICS)

The Incident Command System (ICS) is a management tool that is rapidly being adopted by professional emergency responders throughout the country. ICS provides a coordinated system of command, communications, organization, and accountability in managing emergency events. Due to the wide spread use of ICS, Amateur Radio operators should be familiar with the system, as well as how they will interface with agencies employing ICS.

Integral to the ICS is the concept of *Unified Command*. There is only one boss, the Incident Commander, who is responsible for the overall operation. For any incident, there are a number of functions that must be performed ranging from planning and logistics to handling the press. The functional requirements of planning, logistics, operations, and finance are always present despite the size of the incident. They may be handled by a single individual for a small incident, or a "Command Staff" in a large incident. Another characteristic of ICS is "span of control." In simple terms, any manager should only directly manage a small number of people. ICS uses the number of five for organizational purposes. The number five isn't hard and fast, but provides a useful organizational guide line.

How does the Amateur Radio volunteer fit into the Incident Command System? We are expected to be communicators, and within the ICS, this would place us in the Logistics Section in the Service Branch as part of the Communications Unit. The communications unit provides all communications services for the operation.

# HAZARDOUS MATERIAL INCIDENT DEPLOYMENTS

Topic	Page
HAZMAT INCIDENTS	23
HAZMAT INCIDENT GUIDELINES	25

## HAZMAT INCIDENTS

The term “hazardous materials” (HAZMAT) refers to any substances or materials which, if released in an uncontrolled manner (eg, spilled), can be harmful to people, animals, crops, water systems, or other elements of the environment. The list is long and includes explosives, gases, flammable and combustible liquids, flammable solids or substances, oxidizing substances, poisonous and infectious substances, radioactive materials, and corrosives.

One of the major problems is to determine what chemicals are where and in what quantities. Various organizations in the US have established or defined classes or lists of hazardous materials for regulatory purposes or for the purpose of providing rapid indication of the hazards associated with individual substances. As the primary regulatory agency concerned with the safe transportation of such materials in interstate commerce, the US Department of Transportation (DOT) has established definitions of various classes of hazardous materials, established placarding and marking requirements for containers and packages, and adopted an international cargo commodity numbering system.

The DOT requires that all freight containers, trucks and rail cars transporting these materials display placards identifying the hazard class or classes of the materials they are carrying. The placards are diamond-shaped, 10-inches on a side, color-coded and show an icon or graphic symbol depicting the hazard class. They are displayed on the ends and sides of transport vehicles. A four-digit identification number may be displayed on the placard or on an adjacent rectangular orange panel. If you have spent time on the roads you have undoubtedly seen these placards or panels displayed on trucks and

railroad tank cars. You may recognize some of the more common ones, such as 1993, which covers a multitude of chemicals including road tar, cosmetics, diesel fuel and home heating oil. Or you may have seen tankers placarded 1203 filling the underground tanks at the local gasoline station.

In addition to the placards, warning labels must be displayed on most packages containing hazardous materials. The labels are smaller versions of the placards (4-inches on a side). In some cases, more than one label must be displayed, in which case the labels must be placed next to each other. In addition to labels for each of the DOT hazard classes other labels with specific warning messages may be required. Individual containers also have to be accompanied by shipping papers (if you can safely get close enough!) which contain the proper shipping name, the four-digit ID number and other important information about the hazards of the material.

Details of the placards and emergency response procedures can be found in the comprehensive DOT *Emergency Response Guidebook*, copies of which may be available for review at your local CD, police, sheriff or fire department. You may also want to consult your Local Emergency Planning Committee (LEPC) or State Emergency Response Commission (SERC) concerning what role Amateur Radio might have in your local plan. For more information about hazardous materials in general, contact FEMA, Technological Hazards Division, Federal Center Plaza, 500 C St, SW, Washington, DC, 20472 (202) 646-2861.



## HAZMAT INCIDENT GUIDELINES

- **Approach the scene cautiously - from uphill and upwind. If you have binoculars, use them!**
- **Try to identify the material by any *one* of the following:**
  - **The four-digit number on a placard or orange panel**
  - **The four-digit number (preceded by the initials "UN/NA") on a shipping paper or package**
  - **The name of the material on the shipping paper, placard or package.**
- **Call for help immediately and let the experts handle the situation. Do not attempt to take any action beyond your level of training. Know what you are capable of doing.**

# BASIC OPERATING PRINCIPLES

<b>Topic</b>	<b>Page</b>
<b>PRINCIPLES OF REPEATER OPERATION</b>	<b>27</b>
<b>PRINCIPLES OF DISASTER COMMUNICATIONS</b>	<b>28</b>

## PRINCIPLES OF REPEATER OPERATION

1. **Use minimum power.** Otherwise, especially in heavily populated areas, you may run the risk of keying more than one repeater, thus causing unnecessary QRM. Low power also conserves batteries.
2. **Use simplex, whenever possible.** ARRL recommends 146.52 MHz, but it's a good idea to have at least one other simplex channel available. Use a gain antenna at fixed locations for simplex operation.
3. **Observe the "pause" procedure between exchanges.** When it is your turn to transmit, after the transmitting station stands by, count to two or three before pressing your transmit switch.
4. **Listen much, transmit little.** Announce your presence on a repeater when you are certain of being able to assist in an emergency, and don't tie it up with idle chatter.
5. **Monitor local ARES net frequency,** when otherwise not busy.
6. **Think before you talk.** Anyone with an inexpensive public-service-band receiver can monitor. Stick to facts, control your emotions. Remember, during an emergency is the time when you are most apt to act and speak rashly.
7. **Articulate, don't slur.** Speak close to your mike, but talk across it, not into it. Keep your voice down. In an emergency situation one often gets excited and tends to shout. Talk slowly, calmly--this is the mark of an experienced communicator.

## PRINCIPLES OF DISASTER COMMUNICATION

1. **Keep the QRM level down.** In a disaster, crucial stations may be weak. All other stations should remain silent unless they are called upon. If you're not sure you should transmit, don't.
2. **Monitor established disaster frequencies.** Many ARES localities and some geographical areas have established disaster frequencies where someone is always (or nearly always) monitoring for possible calls.
3. **Avoid spreading rumors.** During and after a disaster situation, especially on the phone bands, you may hear almost anything. Unfortunately, much misinformation is transmitted. Rumors are started by expansion, deletion, amplification or modification of words, exaggeration or interpretation. All addressed transmissions should be officially authenticated as to their source. These transmissions should be repeated word for word, if at all, and only when specifically authorized.
4. **Authenticate all messages.** Every message which purports to be of an official nature should be written and signed. Whenever possible, amateurs should avoid initiating disaster or emergency traffic themselves. We do the communicating; the agency officials we serve supply the content of the communications.
5. **Strive for efficiency.** Whatever happens in an emergency, you will find hysteria and some amateurs who are activated by the thought that they must be sleepless heroes. Instead of operating your own station full time at the expense of your health and efficiency, it is much better to serve a shift at one of the best-located and best-equipped stations, suitable for the work at hand, manned by relief shifts of the best-qualified operators. This reduces interference and secures well-operated stations.

6. **Select the mode and band to suit the need.** It is a characteristic of all amateurs to believe that their favorite mode and band is superior to all others. However, the merits of a particular band or mode in a communications emergency should be evaluated impartially with a view to the appropriate use of bands and modes. There is, of course, no alternative to using what happens to be available, but there are ways to optimize available communications.

7. **Use all communications channels intelligently.** While the prime object of emergency communications is to save lives and property (anything else is incidental), Amateur Radio is a secondary communications means; normal channels are primary and should be used if available. Emergency channels other than amateur which are available in the absence of amateur channels should be utilized without fear of favoritism in the interest of getting the message through.

8. **Don't "broadcast."** Some stations in an emergency situation have a tendency to emulate "broadcast" techniques. While it is true that the general public may be listening, our transmissions are not and should not be made for that purpose.

9. **NTS and ARES leadership coordination.** Within the disaster area itself, the ARES is primarily responsible for emergency communications support. The first priority of those NTS operators who live in or near the disaster area is to make their expertise available to their Emergency Coordinator (EC) where and when needed. For timely and effective response, this means that NTS operators should talk to their ECs before the time of need so that they will know how to best respond.

# MESSAGE FORMATS

<b>Topic</b>	<b>Page</b>
<b>DISASTER WELFARE MESSAGE FORM</b>	<b>31</b>
<b>ARRL RADIOGRAM FORM</b>	<b>32</b>
<b>ARRL MESSAGE FORM</b>	<b>33</b>
<b>ARRL MESSAGE PRECEDENCES</b>	<b>34</b>
<b>ARRL MESSAGE HANDLING INSTRUCTIONS</b>	<b>35</b>
<b>EMERGENCY RELIEF NUMBERED RADIOGRAMS</b>	<b>36</b>



# DISASTER WELFARE MESSAGE FORM

Number	Precedence	HX	Station of Origin	Check	Place of Origin	Time Filed	Date

**TO:**

**Message Receipt or Delivery Information**  
 Operator and station: \_\_\_\_\_  
 Sent to: \_\_\_\_\_  
 Delivered to: \_\_\_\_\_  
 Date: \_\_\_\_\_ Time: \_\_\_\_\_

**Telephone number:**

**(Circle not more than two standard texts from list below)**

- ARL ONE                    Everyone safe here. Please don't worry.
- ARL TWO                    Coming home as soon as possible.
- ARL THREE                Am in \_\_\_\_\_ hospital. Receiving excellent care and recovering fine.
- ARL FOUR                Only slight property damage here. Do not be concerned about disaster reports.
- ARL FIVE                Am moving to new location. Send no further mail or communications. Will inform you of new address when relocated.
- ARL SIX                    Will contact you as soon as possible.
- ARL SIXTY FOUR        Arrived safely at \_\_\_\_\_

Time	Date	Telephone	Signature	Name

**THE AMERICAN RADIO RELAY LEAGUE  
RADIOGRAM  
VIA AMATEUR RADIO**

NUMBER	PRECEDENCE	HX	STATION OF ORIGIN	CHECK	PLACE OF ORIGIN	TIME FILED	DATE
--------	------------	----	-------------------	-------	-----------------	------------	------

**TO:**

**RECEIVED AT:**

STATION \_\_\_\_\_ PHONE \_\_\_\_\_  
 NAME \_\_\_\_\_  
 ADDRESS \_\_\_\_\_

**Telephone number:**

<b>REC'D</b>	FROM	DATE	TIME	<b>SENT</b>	TO	DATE	TIME
--------------	------	------	------	-------------	----	------	------



# AMATEUR MESSAGE FORM

Every formal radiogram message originated and handled should contain the following components in the order given.

I PREAMBLE	MESSAGE EXAMPLE
<ul style="list-style-type: none"> <li>a. Number (begin with 1 each month or year)</li> <li>b. Precedence (R, W, P or EMERGENCY)</li> <li>c. Handling Instructions (optional)</li> <li>d. Station of Origin (first amateur handler)</li> <li>e. Check (number of words/groups in text only)</li> <li>f. Place of origin (not necessarily location of station of origin)</li> <li>g. Time Filed (optional with originating station)</li> <li>h. Date (must agree with date of time filed)</li> </ul>	<p>I 1 R HXG W1AW 8 NEWINGTON CT 1830Z JULY 1  <i>a b c d e f g h</i></p> <p>II DONALD SMITH            164 EAST SIXTH AVE            NORTH RIVER CITY MO 00789            733 4968</p> <p>III HAPPY BIRTHDAY X SEE YOU SOON X LOVE</p> <p>IV DIANA</p> <p>Note that X, when used in the text as punctuation, counts as a word.</p>
<p>II ADDRESS (as complete as possible, include zip and telephone)</p>	
<p>III TEXT (limit to 25 words or less, if possible)</p>	
<p>IV SIGNATURE</p>	

## ARRL MESSAGE PRECEDENCES

**EMERGENCY**--Any message having life and death urgency to any person or group of persons, which is transmitted by Amateur Radio in the absence of regular commercial facilities. This includes official messages of welfare agencies during emergencies requesting supplies, materials or instructions vital to relief to stricken populace in emergency areas. On CW, RTTY, AMTOR and packet this designation will always be spelled out. When in doubt, do not use this designation.

**PRIORITY**--Use abbreviation P on CW, RTTY, AMTOR and packet. This classification is for important messages having a specific time limit, official messages not covered in the emergency category, press dispatches and emergency-related traffic not of the utmost urgency.

**WELFARE**--This classification, abbreviated as W on CW, RTTY, AMTOR and packet, refers to either an inquiry as to the health and welfare of an individual in the disaster area or an advisory from the disaster area that indicates all is well. Welfare traffic is handled only after all emergency and priority traffic is cleared. The Red Cross equivalent to an incoming Welfare message is DWI (Disaster Welfare Inquiry).

**ROUTINE**--Most traffic in normal times will bear this designation. In disaster situations, traffic labeled Routine (R on CW, RTTY, AMTOR and packet) should be handled last, or not at all when circuits are busy with higher-precedence traffic.

## ARRL MESSAGE HANDLING INSTRUCTIONS

Handling instructions (HX) convey special instructions to message handling and delivering operators. The instruction is inserted in the message preamble between the precedence and the station of origin. Its use is optional with the originating stations, but once inserted is mandatory with all relaying stations.

PROSIGN	Instruction
<b>HXA</b>	(Followed by number) Collect landline delivery authorized by addressee within...miles. (If no number, authorization is unlimited.)
<b>HXB</b>	(Followed by number) Cancel message if not delivered within...hours of filing time; service originating station.
<b>HXC</b>	Report date and time of delivery (TOD) to originating station.
<b>HXD</b>	Report to originating station the identity of station from which received, plus date and time. Report identity of station to which relayed, plus date and time, or if delivered report date, time and method of delivery.
<b>HXE</b>	Delivering station get reply from addressee, originate message back.
<b>HXF</b>	(Followed by number.) Hold delivery until...(date).
<b>HXG</b>	Delivery by mail or landline toll call not required. If toll or other expense involved, cancel message and service originating station.

## ARRL EMERGENCY RELIEF NUMBERED RADIOGRAMS

The letters ARL are inserted in the preamble in the check and in the text before spelled out numbers, which represent texts from this list. Note that some ARL texts include insertion of information. Example: NR 1 W W1AW ARL 4 NEWINGTON CONN DEC 25 DONALD R. SMITH 164 EAST SIXTH AVE NORTH RIVER CITY MO PHONE 733-3968 BT ARL ONE ARL TWO BT DIANA AR.

ONE	Everyone safe here. Please don't worry.
TWO	Coming home as soon as possible.
THREE	Am in ____ hospital. Receiving excellent care and recovering fine.
FOUR	Only slight property damage here. Do not be concerned about disaster reports.
FIVE	Am moving to new location. Send no further mail. Will inform you of new address when relocated.
SIX	Will contact you ASAP.

SEVEN	Please reply by Amateur Radio through the amateur delivering this message. This is a free public service.
EIGHT	Need additional ____ mobile or portable equipment for immediate emergency use.
NINE	Additional ____ radio operators needed to assist with emergency at this location.
TEN	Please contact _____. Advise to standby and provide further emergency information, instructions or assistance. (continued next page).

ELEVEN	Establish Amateur Radio emergency communications with _____ on _____ MHz.
TWELVE	Anxious to hear from you. No word in some time. Please contact me as soon as possible.
THIRTEEN	Medical emergency situation exists here.
FOURTEEN	Situation here becoming critical. Losses and damage from _____ increasing.
FIFTEEN	Please advise your condition and what help is needed.
SIXTEEN	Property damage very severe in this area.
SEVENTEEN	REACT communications services also available. Establish REACT communication with _____ on channel _____.
EIGHTEEN	Please contact me as soon as possible at _____.
NINETEEN	Request health and welfare report on _____(name, address, phone).

TWENTY	Temporarily stranded. Will need some assistance. Please contact me at _____.
TWENTY ONE	Search and Rescue assistance is needed by local authorities here. Advise availability.
TWENTY TWO	Need accurate information on the extent and type of conditions now existing at your location. Please furnish this information and reply without delay.
TWENTY THREE	Report at once the accessibility and best way to reach your location.
TWENTY FOUR	Evacuation of residents from this area urgently needed. Advise plans for help.
TWENTY FIVE	Furnish as soon as possible the weather conditions at your location.
TWENTY SIX	Help and care for evacuation of sick and injured from this location needed at once.

# LOCAL NET/CONTACT INFORMATION

<b>Topic</b>	<b>Page</b>
<b>LOCAL EMERGENCY NET INFORMATION</b>	<b>39</b>
<b>LOCAL RED CROSS CHAPTER OFFICES</b>	<b>40</b>
<b>LOCAL EMERGENCY OPERATIONS CENTERS</b>	<b>41</b>
<b>LOCAL/COUNTY PUBLIC SAFETY OFFICES</b>	<b>42</b>
<b>ARRL ARES EMERGENCY COORDINATORS</b>	<b>43</b>
<b>OTHER EMERGENCY INFORMATION CONTACTS</b>	<b>44</b>
<b>LOCAL REPEATER DIRECTORY</b>	<b>45</b>
<b>LOCAL PACKET DIRECTORY</b>	<b>47</b>



## LOCAL EMERGENCY NET INFORMATION

Day	Time	Net Name	Frequency	Sponsor
		ARES Net		
		RACES Net		
		SKYWARN Net		
		NTS Section Net		
		NTS Local Net		

## LOCAL RED CROSS CHAPTER OFFICES

Chapter Name	Address	Telephone	E-Mail Address	Station Call Sign



## LOCAL/COUNTY EMERGENCY OPERATIONS CENTERS

EOC Name	Address	Telephone	E-Mail Address	Station Call Sign

## LOCAL/COUNTY PUBLIC SAFETY AGENCY OFFICES

Agency/Office Name	Address	Telephone	E-Mail Address	Station Call Sign
State Police				
Local Police				
Sheriff				
Fire Department				
Ambulance				
Civil Defense				
National Weather Service				



## SECTION/DISTRICT/COUNTY ARRL ARES EMERGENCY COORDINATORS

Name and Call Sign	Title	Address	Telephone	E-Mail Address
	Emergency Coordinator (EC)			
	Assistant EC			
	District EC			
	Section EC			
	Section Manager			
	Net Manager			

## OTHER EMERGENCY INFORMATION CONTACTS

Name and Call Sign	Title	Address	Telephone	E-Mail Address

## LOCAL REPEATER DIRECTORY

Location	Output	Input	Callsign	Notes
				Emergency Power
				Emergency Power

Location	Output	Input	Callsign	Notes
				Emergency Power
				Emergency Power

## LOCAL PACKET DIRECTORY

Location	Frequency	Alias	Callsign	Notes
				Emergency Power
				Emergency Power

Location	Frequency	Alias	Callsign	Notes
				Emergency Power
				Emergency Power

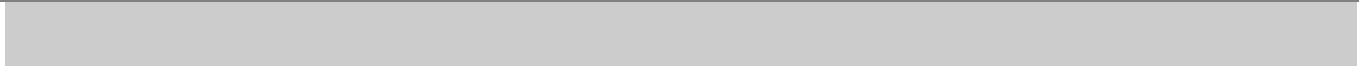



## ARRL SECTION ARES MAP

<<Paste your ARRL Section ARES Map Here>>

## **SECTION EMERGENCY PLAN**

<<Paste your section emergency operations plan here>>

# OPERATING AIDS

Operating Aid	Page
<b>PACKET BBS COMMANDS</b>	<b>52</b>
<b>ARRL COMMUNICATIONS PROCEDURES</b>	<b>53</b>
<b>ITU PHONETIC ALPHABET</b>	<b>54</b>
<b>R-S-T SYSTEM</b>	<b>55</b>
<b>INTERNATIONAL Q SIGNALS</b>	<b>56</b>
<b>ABBREVIATIONS, PROSIGNS, PROWORDS</b>	<b>57</b>

## SIMPLE PACKET BBS COMMANDS

Abbreviation	Command	Function
B	BYE	Disconnect from the mailbox
CM	Copy Msg	Make a copy of a message for another station
D	Download	Download files. (Read files that are in the BBS)
E	Edit TFC	Edit the message header (To, From, etc)
H	Help	Gives a list of BBS commands
J	WHO	Listing of stations recently heard or connected to the mailbox
K	Kill	Kill (erase) a message
L	List	List messages (several variations available)
N	Name	Enter your Name, QTH, Zip, and Home Mail box
R	Read	Read a message
S	Send	Send a message
U	Upload	Upload a file to the BBS
W	What	What files are on the BBS

## ARRL COMMUNICATIONS PROCEDURES

<i>Voice</i>	<i>Code</i>	<i>Function</i>
<b>Go ahead</b>	<b>K</b>	Used after calling CQ, or at the end of a transmission, to indicate any station is invited to transmit.
<b>Over</b>	<b>AR</b>	Used after a call to a specific station, to indicate end of instant transmission.
	<b>KN</b>	Used at the end of any transmission when only the specific station contacted is invited to answer.
<b>Stand by or wait Roger</b>	<b>AS</b>	A temporary interruption of the contact.
	<b>R</b>	Indicates a transmission has been received correctly and in full.
<b>Clear</b>	<b>SK</b>	End of contact. SK is sent before the final identification.
<b>Leaving the air</b>	<b>CL</b>	Indicates that a station is going off the air, and will not listen for any further calls. CL is sent after the final identification.

## ITU PHONETIC ALPHABET

Word list adopted by the International Telecommunication Union.

<b>A</b>	<b>ALFA</b>	<b>N</b>	<b>NOVEMBER</b>
<b>B</b>	<b>BRAVO</b>	<b>O</b>	<b>OSCAR</b>
<b>C</b>	<b>CHARLIE</b>	<b>P</b>	<b>PAPA</b>
<b>D</b>	<b>DELTA</b>	<b>Q</b>	<b>QUEBEC</b>
<b>E</b>	<b>ECHO</b>	<b>R</b>	<b>ROMEO</b>
<b>F</b>	<b>FOXTROT</b>	<b>S</b>	<b>SIERRA</b>
<b>G</b>	<b>GOLF</b>	<b>T</b>	<b>TANGO</b>
<b>H</b>	<b>HOTEL</b>	<b>U</b>	<b>UNIFORM</b>
<b>I</b>	<b>INDIA</b>	<b>V</b>	<b>VICTOR</b>
<b>J</b>	<b>JULIETT</b>	<b>W</b>	<b>WHISKEY</b>
<b>K</b>	<b>KILO</b>	<b>X</b>	<b>X-RAY</b>
<b>L</b>	<b>LIMA</b>	<b>Y</b>	<b>YANKEE</b>
<b>M</b>	<b>MIKE</b>	<b>Z</b>	<b>ZULU</b>

## THE R-S-T SYSTEM

### READABILITY

- 1 -- Unreadable
- 2 -- Barely readable, occasional words distinguishable.
- 3 -- Readable with considerable difficulty.
- 4 -- Readable with practically no difficulty.
- 5 -- Perfectly readable.

### SIGNAL STRENGTH

- 1 -- Faint signals, barely perceptible.
- 2 -- Very weak signals.
- 3 -- Weak signals.
- 4 -- Fair signals.
- 5 -- Fairly good signals.
- 6 -- Good signals.
- 7 -- Moderately strong signals.
- 8 -- Strong signals.
- 9 -- Extremely strong signals.

### TONE

- 1 -- Sixty cycle a.c. or less, very rough and broad.
- 2 -- Very rough a.c., very harsh and broad.
- 3 -- Rough a.c. tone, rectified but not filtered.
- 4 -- Rough note, some trace of filtering.
- 5 -- Filtered rectified a.c. but strongly ripple-modulated.
- 6 -- Filtered tone, definite trace of ripple modulation.
- 7 -- Near pure tone, trace of ripple modulation.
- 8 -- Near perfect tone, slight trace of modulation.
- 9 -- Perfect tone, no trace of ripple or modulation of any kind.

## INTERNATIONAL Q SIGNALS

SIGNAL	MESSAGE
QRA	What is the name of your station?
QRG	What's my exact frequency?
QRH	Does my frequency vary?
QRI	How is my tone? (1-3)
QRK	What is my signal intelligibility? (1-5)
QRL	Are you busy?
QRM	Is my transmission being interfered with?
QRN	Are you troubled by static?
QRO	Shall I increase transmitter power?
QRP	Shall I decrease transmitter power?
QRQ	Shall I send faster?
QRS	Shall I send slower?
QRT	Shall I stop sending?
QRU	Have you anything for me? (Answer in negative)
QRV	Are you ready?
QRW	Shall I tell ..... you're calling him?
QRX	When will you call again?
QRZ	Who is calling me?
QSA	What is my signal strength? (1-5)
QSB	Are my signals fading?
QSD	Is my keying defective?

QSG	Shall I send ..... messages at a time?
QSK	Can you work breakin?
QSL	Can you acknowledge receipt?
QSM	Shall I repeat the last message sent?
QSO	Can you communicate with ..... direct?
QSP	Will you relay to ..... ?
QSV	Shall I send a series of V's?
QSW	Will you transmit on ..... ?
QSX	Will you listen for ..... on ..... ?
QSY	Shall I change frequency?
QSZ	Shall I send each word/group more than once? (Answer send twice or ..... )
QTA	Shall I cancel number ..... ?
QTB	Do you agree with my word count? (Answer negative)
QTC	How many messages have you to send?
QTH	What is your location?
QTR	What is your time?
QTV	Shall I stand guard for you ..... ?
QTX	Will you keep your station open for further communication with me?
QUA	Have you news of ..... ?



## ABBREVIATIONS, PROSIGNS, PROWORDS

CW	PHONE
—	(Separation between parts of address or signature.)
AA	All after (use to get fills).
AB	All before (used to get fills).
ADEE	Addressee (name of person to whom message addressed).
ADR	Address (second part of message).
—	End of message (end of record copy).
ARL	(Used with "check " indicates use of ARRL numbered message in text).
—	Stand by; wait.
B	More (another message to follow).
—	Break; break me; break-in (interrupt transmission on cw. Quick check on phone).
—	Separation (break) between address and text; between text and signature.
C	Correct; yes.
CFM	Confirm. (Check me on this).
CK	Check.
DE	From; this is (preceding identification).

—	(Error in sending. Transmission continues with last word correctly sent.)
HH	(Handling instructions. Optional part of preamble.) Initial(s). Single letter(s) to follow.
HX	
—	Repeat; I say again. (Difficult or unusual words or groups.)
IMI	
K	Go ahead; over; reply expected. (Invitation to transmit .)
N	Negative; incorrect; no more. (No more messages to follow.)
NR	Number. (Message follows.)
PBL	Preamble (first part of message)..... Read back. (Repeat as received.)
R	Roger; point. (Received; decimal point.)
SIG	Signed; signature (last part of message.)
—	Out; clear (end of communications no reply expected.)
SK	
TU	Thank you.
WA	Word after (used to get fills.)
WB	Word before (used to get fills.) ..... Speak slower. .... Speak faster.

# HURRICANE INFORMATION

<b>Topic</b>	<b>Page</b>
<b>SAFFIR/SIMPSON HURRICANE SCALE</b>	<b>59</b>
<b>HURRICANE TRACKING CHART</b>	<b>60</b>

## SAFFIR/SIMPSON HURRICANE SCALE

Category	Pressure	Winds	Surge	Damage
1	28.94"	74-95 MPH	4-5 ft	Minimal. Primarily to trees, foliage, and unanchored mobile homes. No real damage to other structures. Some small craft may be torn from moorings.
2	28.50"	96-110 MPH	6-8 ft	Moderate, some trees blown down. Some window, door and roofing damage. Small craft torn from moorings in unprotected anchorages. Some evacuation of shoreline residences and low-lying islands.
3	27.91"	111-130 MPH	9-12 ft	Extensive. Large trees blown down. Some structural damage to small buildings. Mobile homes destroyed. Serious coastal flooding. Many small structures near coast destroyed by wind and waves. Almost all small boats torn from moorings.
4	27.17"	131-155 MPH	13-18 ft	Extreme. Extensive damage to roofs on many small residences. Terrain 10 feet or less above sea level flooded. Escape routes cut by rising water 3 to 5 hours before center arrives. Massive coastal evacuation required.
5	27.16"	156 MPH +	18 ft +	Catastrophic. Complete failure of roofs on residences and many commercial structures. Small buildings overturned or blown away. Massive evacuation from low ground within 5-10 miles of the coast.



# APPENDICES

Appendix	Topic	Page
<b>ONE:</b>	<b>FCC RULES, PROVIDING EMERGENCY COMMUNICATIONS</b>	<b>62</b>
<b>TWO:</b>	<b>THIRD PARTY TRAFFIC COUNTRIES LIST</b>	<b>66</b>
<b>THREE:</b>	<b>ARRL STANDARD POWER CONNECTOR</b>	<b>68</b>
<b>FOUR:</b>	<b>SECTION EMERGENCY COORDINATORS</b>	<b>69</b>
<b>FIVE:</b>	<b>SECTION WIDE EMERGENCY NETS</b>	<b>75</b>
<b>SIX:</b>	<b>WIDE AREA DISASTER RELIEF NETS</b>	<b>79</b>
<b>SEVEN:</b>	<b>MUTUAL ASSISTANCE TEAM (ARESMT) CONCEPT</b>	<b>80</b>
<b>EIGHT:</b>	<b>FEDERAL RESPONSE PLAN</b>	<b>83</b>
<b>NINE:</b>	<b>NATIONAL DISASTER MEDICAL SYSTEM</b>	<b>85</b>
<b>TEN:</b>	<b>WILDERNESS PROTOCOL</b>	<b>87</b>

## APPENDIX ONE

### FCC Rules: Subpart E—Providing Emergency Communications

#### §97.401 Operation during a disaster.

(a) When normal communication systems are overloaded, damaged or disrupted because a disaster has occurred, or is likely to occur, in an area where the amateur service is regulated by the FCC, an amateur station may make transmissions necessary to meet essential communication needs and facilitate relief actions.

(b) When normal communication systems are overloaded, damaged or disrupted because a natural disaster has occurred, or is likely to occur, in an area where the amateur service is not regulated by the FCC, a station assisting in meeting essential communication needs and facilitating relief actions may do so only in accord with ITU Resolution No. 640 (Geneva, 1979). The 80 m, 75 m, 40 m, 30 m, 20 m, 17 m, 15 m, 12 m, and 2 m bands may be used for these purposes.

(c) When a disaster disrupts normal communication systems in a particular area, the FCC may declare a temporary state of communication emergency. The declaration will set forth any special conditions and special rules to be observed by stations during the communication emergency. A request for a declaration of a temporary state of emergency should be directed to the EIC in the area concerned.

(d) A station in, or within 92.6 km of, Alaska may transmit emissions J3E and R3E on the channel at 5.1675 MHz for emergency communications. The channel must be shared with stations licensed in the Alaska-private fixed service. The transmitter power must not exceed 150 W.

**§97.403 Safety of life and protection of property.**

No provision of these rules prevents the use by an amateur station of any means of radiocommunication at its disposal to provide essential communication needs in connection with the immediate safety of human life and immediate protection of property when normal communication systems are not available.

**§97.405 Station in distress.**

(a) No provision of these rules prevents the use by an amateur station in distress of any means at its disposal to attract attention, make known its condition and location, and obtain assistance.

(b) No provision of these rules prevents the use by a station, in the exceptional circumstances described in paragraph (a), of any means of radiocommunications at its disposal to assist a station in distress.

**§97.407 Radio amateur civil emergency service.**

(a) No station may transmit in RACES unless it is an FCC-licensed primary, club, or military recreation station and it is certified by a civil defense organization as registered with that organization, or it is an FCC-licensed RACES station. No person may be the control operator of a RACES station, or may be the control operator of an amateur station transmitting in RACES unless that person holds a FCC-issued amateur operator license and is certified by a civil defense organization as enrolled in that organization.

(b) The frequency bands and segments and emissions authorized to the control operator are available to stations transmitting communications in RACES on a shared basis with the amateur service. In the event of an emergency which necessitates the invoking of the President's War Emergency Powers under the provisions of §706 of the Communications Act of 1934, as amended, 47 U.S.C. §606, RACES stations and amateur stations participating in RACES may only transmit on the following frequencies:

(1) The 1800-1825 kHz, 1975-2000 kHz, 3.50-3.55 MHz, 3.93-3.98 MHz, 3.984-4.000 MHz, 7.079-7.125 MHz, 7.245-7.255 MHz, 10.10-10.15 MHz, 14.047-14.053 MHz, 14.22-14.23 MHz, 14.331-14.350 MHz, 21.047-

21.053 MHz, 21.228-21.267 MHz, 28.55-28.75 MHz, 29.237-29.273 MHz, 29.45-29.65 MHz, 50.35-50.75 MHz, 52-54 MHz, 144.50-145.71 MHz, 146-148 MHz, 2390-2450 MHz segments;

(2) The 1.25 m, 70 cm and 23 cm bands; and

(3) The channels at 3.997 MHz and 53.30 MHz may be used in emergency areas when required to make initial contact with a military unit and for communications with military stations on matters requiring coordination.

(c) A RACES station may only communicate with:

(1) Another RACES station;

(2) An amateur station registered with a civil defense organization;

(3) A United States Government station authorized by the responsible agency to communicate with RACES stations;

(4) A station in a service regulated by the FCC whenever such communication is authorized by the FCC.

(d) An amateur station registered with a civil defense organization may only communicate with:

(1) A RACES station licensed to the civil defense organization with which the amateur station is registered;

(2) The following stations upon authorization of the responsible civil defense official for the organization with which the amateur station is registered:

(i) A RACES station licensed to another civil defense organization;

(ii) An amateur station registered with the same or another civil defense organization;

(iii) A United States Government station authorized by the responsible agency to communicate with RACES stations; and

(iv) A station in a service regulated by the FCC whenever such communication is authorized by the FCC.

(e) All communications transmitted in RACES must be specifically authorized by the civil defense organization for the area served. Only civil defense communications of the following types may be transmitted:



(1) Messages concerning impending or actual conditions jeopardizing the public safety, or affecting the national defense or security during periods of local, regional, or national civil emergencies;

(2) Messages directly concerning the immediate safety of life of individuals, the immediate protection of property, maintenance of law and order, alleviation of human suffering and need, and the combating of armed attack or sabotage;

(3) Messages directly concerning the accumulation and dissemination of public information or instructions to the civilian population essential to the activities of the civil defense organization or other authorized governmental or relief agencies; and

(4) Communications for RACES training drills and tests necessary to ensure the establishment and maintenance of orderly and efficient operation of the RACES as ordered by the responsible civil defense organizations served. Such drills and tests may not exceed a total time of 1 hour per week. With the approval of the chief officer for emergency planning in the applicable State, Commonwealth, District or territory, however, such tests and drills may be conducted for a period not to exceed 72 hours no more than twice in any calendar year.

## **APPENDIX TWO**

## COUNTRIES THAT SHARE A THIRD PARTY TRAFFIC AGREEMENT WITH THE UNITED STATES:

V2	Antigua/Barbuda	V6	Federated States of	ZP	Paraguay
LU	Argentina		Micronesia	OA	Peru
VK	Australia	C5	Gambia	DU	Philippines
V3	Belize	9G	Ghana	VR6	Pitcairn Island*
CP	Bolivia	J3	Grenada	V4	St. Christopher/Nevis
T9	Bosnia-Herzegovina	TG	Guatemala	J6	St. Lucia
PY	Brazil	8R	Guyana	J8	St. Vincent
VE	Canada	HH	Haiti	9L	Sierra Leone
CE	Chile	HR	Honduras	3DA	Swaziland
HK	Colombia	4X	Israel	9Y	Trinidad/Tobago
D6	Comoros	6Y	Jamaica	GB	United Kingdom **
TI	Costa Rica	JY	Jordan	CX	Uruguay
CO	Cuba	EL	Liberia	YV	Venezuela
HI	Dominican Republic	V7	Marshall Islands	4U1ITU	- ITU, Geneva
J7	Dominica	XE	Mexico	4U1VIC	- VIC, Vienna
HC	Ecuador	YN	Nicaragua		
YS	El Salvador	HP	Panama		

\* Since 1970, there has been an informal agreement between the United Kingdom and the US, permitting Pitcairn and US amateurs to exchange messages concerning medical emergencies, urgent need for equipment or supplies, and private or personal matters of island residents.

\*\* Limited to special-event stations with callsign prefix GB (GB3 excluded).

**Note: US licensed amateurs may operate in the following US territories under their FCC license: The Northern Marianas Islands, Guam, Johnston Island, Midway Island, Kure Island, American Samoa, Wake Island, Wilkes Island, Peale Island, The Commonwealth of Puerto Rico and the US Virgin Islands.**

## **TEMPORARY THIRD PARTY TRAFFIC AGREEMENTS:**

(Note: During major disaster situations, administrations of countries may request temporary third party traffic agreements to facilitate the passage of emergency and health and welfare messages. W1AW bulletins carry announcements of temporary agreements.)

Countries: \_\_\_\_\_  
\_\_\_\_\_  
\_\_\_\_\_

## **APPENDIX THREE**

### **ARRL STANDARD POWER CONNECTOR**

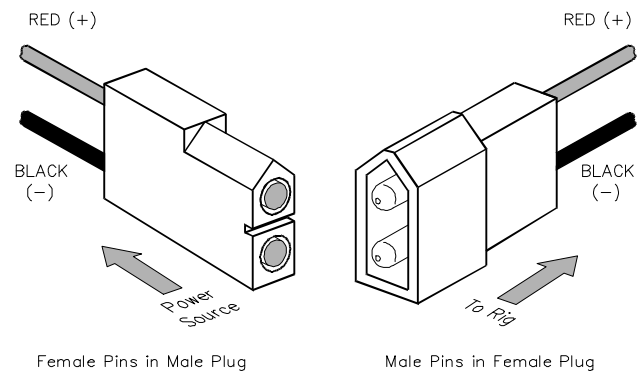

MOLEX Series 1545 connector for use in promoting compatibility and interchangeability among personal VHF/UHF radio equipment at disaster sites. Polarity should always be verified prior to connecting to radios and power supplies.

## APPENDIX FOUR

# SECTION EMERGENCY COORDINATORS



ALABAMA	J. Rick Kimbrell, KC4RNF P O Box 10 Winfield, AL 35594 205-487-6783		Canoga Park, CA 91304 818-709-4229
ALASKA	Russell Ely, WL7LP 1004 Sirlin Dr. North Pole, AK 99705 907-488-7388	ORANGE	Fred W. Finke, KA6IXY 32280 Machado St. Lake Elsinore, CA 92530 909-674-1731; 714-801-1241
ARIZONA	Cletis Boan, AK6Y P O Box 50351 Parks, AZ 86018 602-635-2355	SACRAMENTO VALLEY	Andrew L. Robinson, WD9EKX 877 Bille Rd. Paradise, CA 95969 916-872-2819
ARKANSAS	Jim Blackmon, KB5IFV 1008 Pine St. Arkadelphia, AR 71923 501-246-7833	SAN DIEGO	Robert Ryan, KC6VVT PO Box 314 Imperial Beach, CA 91933-0314 619-691-0098
CALIFORNIA		SAN FRANCISCO	Dale Westerterp, WB6TMS P O Box 478 Petaluma, CA 94953 707-762-9414
EAST BAY	Mark Keiser, N4OGL 4262 Sora Terr. Fremont, CA 94553	SAN JOAQUIN VALLEY	Walter Smith, WC6U 1254 Malibu Ct. Tulare, CA 93274-7641 209-688-6058; 209-686-3335
LOS ANGELES	Hank Magid, K6YMJ 21117 Osborne St.		

SANTA BARBARA	Jennifer Roe, AA6MX 2480 N. Verde Court Simi Valley, CA 93065 805-583-3805; 805-583-8600 x 3870	Lake Worth, FL 33463 407-967-1477; 407-533-0588
SANTA CLARA VALLEY	Frederick Fowler, KE6EPM 921 Lakebird Dr. Sunnyvale, CA 94089 408-747-1454	GEORGIA Dale A. Culp, W1BPP 974 Paul Murphy Rd. Moultrie, GA 31768-9125 912-985-7406
COLORADO	Rich Ferguson, KA0DXM 1150 Albion Rd. Boulder, CO 80303 303-499-2871; 303-538-2612	HAWAII & PACIFIC Dennis Carvalho, KH2M P O Box 383743 Waikoloa, HI 76738 808-324-6229
CONNECTICUT	Clark S. Magness, NI1U 23 Snowbird Ct. Guilford, CT 06437	IDAHO Roy Davis, K17EP P O Box 540 Athol, ID 83801-0540 208-683--3782
DELAWARE	Randall K. Carlson, WB0JJX 121 Scarborough Park Dr, Apt 10 Wilmington, DE 19804 302-655-6179	ILLINOIS Robert J. Hajek, W9QBH P O Box 200 Riverside, IL 60546-0200 708-656-0000
FLORIDA		
NORTHERN FLORIDA	Nils Millergren, WA4NDA Rt 1, Box 1010 Wewahitchka, FL 32465 904-639-5302	INDIANA Jim Sellers, K9ZBM 54676 County Rd 8 Middlebury, IN 46540 219-825-5425
SOUTHERN FLORIDA	E. G. "Manny" Papandreas, W4SS 32 Barberton Rd.	IOWA James D. Snapp, NA0R 605 5th Ave SE

	Altoona, IA 50009-1927 515-967-3890		
KANSAS	Joseph Plankinton, WD0DMV 314 NE Sumner St. Topeka, KS 66616 913-296-2231;913-233-00712	WESTERN MASSACHUSETTS	Dennis Zonia, K1VSG 27 Tanner Rd. Webster, MA 01570 508-987-5827; 508-987-0240 (fax)
KENTUCKY	Paul Mitchell, N4DUE 721 Kingston Rd. Lexington, KY 40505-1810 606-299-8919	MICHIGAN	Roger Edwards, WB8WJV 709 S. Almer Caro, MI 48723 517-673-5722; 517-673-7323
LOUISIANA	Gordon McCraw, KA5YDJ 606 Clinebrook Dr. Gretna, LA 70056 504-394-0761; 504-393-3207	MINNESOTA	Gary Peterson, N0ZOD 500 Lyndale Ave. Spring Valley, MN 55975-1121 507-346-7615
MAINE	Arnold P. Smith, KA1LPW RR 6 Box 6475 Augusta, ME 04989 207-622-2915	MISSISSIPPI	H. Eugene Holcombe, Sr. N5ZDF 1124 Perrett Rd. Hazelhurst, MS 39083 601-894-5210
MARYLAND & DC	Michael C. Carr, WA1QAA 8059 Fetlock Court Ellicott City, MD 21043 410-799-0403; 410-993-2500	MISSOURI	Fred Langeneckert, KE0ZG P.O. Box 768 Bridgeton, MO 63044-0768 314-344-9911
MASSACHUSETTS		MONTANA	
EASTERN MASSACHUSETTS	Raymond Wall, N1KXJ 55 Gold St. Whitman, MA 02382		Jim Fuller, N7VMR 527 Yellowstone Ave. Billings, MT 59101 406-248-5835; 406-248-1559

NEBRASKA	Jim Peterson, KF0FO 5208 Cass St. Omaha, NE 68132 402-558-0643; 402-393-5630		Albany, NY 12205 518-458-7567; 518-474-7101
NEVADA	Joseph Giraudo, N7JEH P O Box 868 Elko, NV 89803-0868 702-738-7110; 702-778-8153	NEW YORK CITY- LONG ISLAND	Mario Maltese, WF2T 19 York Place Williston Park, NY 11596 516-873-1011
NEW HAMPSHIRE	Gary Okula, N3CLZ 9 Jay Dr. Londonderry, NH 03053 603-434-4119; 603-474-9521 x 2806	NORTHERN NEW YORK	Darry Roberts, WN2F 91 Cold Brook Rd. Saranac, NY 12981 518-293-6680; 518-293-1216
<i>NEW JERSEY</i>		WESTERN NEW YORK	Edwin Holdsworth, N2EH 518 Parrish Rd. Honeoye Falls, NY 14472 716-624-1929
NORTHERN NEW JERSEY	Gordon Beattie, N2DSY 206 N. Vivyen St. Bergenfield, NJ 07621 201-387-8896; 908-957-6345	NORTH CAROLINA	Bill Mitchell, WB4SGA P O Box 34 Mebane, NC 27302 919-563-1484; 919-563-3324
SOUTHERN NEW JERSEY	Austin Prestwood, W2HOB 8 Dogwood Dr. Burlington, NJ 08016-9710	NORTH DAKOTA	Robert Moeckel, KA0CLH 21 Fenton Ave. Grand Forks, ND 58203 701-777-3659
NEW MEXICO	W. L. "Bill" Kauffman, K6YEJ 1625 36th St. SE Rio Rancho, NM 87124 505-892-0042	OHIO	Larry Solak, WD8MPV 9971 Diagonal Rd. Mantua, OH 44255 330-274-8240; 330-626-4132; 330-274-2811
<i>NEW YORK</i> EASTERN NEW YORK	Anthony Pazzola, WB2BEJ 18-B Pinewood Place		



OKLAHOMA	Bennett L. Basore, W5ZTN 229 N. Knoblock # 26 Stillwater, OK 74075 405-377-0693	SOUTH CAROLINA	Gerald Hensley, K8AFP P O Box 70, N. Main St. Richburg, SC 29729 803-789-3937
OREGON	Lewis N. Williams, WB7NML 3535 NW Glen Ridge Place Corvallis, OR 97330 503-752-1208	SOUTH DAKOTA	Jerry Gathright, WN0Y 926 S. 9th St. Aberdeen, SD 57401 605-229-0514
<i>PENNSYLVANIA</i>			
EASTERN PENNSYLVANIA	Eric D. Olena, WB3FPL RR 5, Box 5687 Mohnton, PA 19540 610-775-0526	TENNESSEE	James Jarvis, WD4EKA 1525 Vance Dr. Bristol, TN 37620 423-764-1941
WESTERN PENNSYLVANIA	Tony Zona, WB3KGT 2485 Dorn Rd. Waterford, PA 16441 814-864-4545; 814-870-1717	NORTH TEXAS	Joe Brown, K5UPN P O Box 2936 Longview, TX 75606 903-297-9431
PUERTO RICO	Guillermo Schwarz, KP3S HC-03 Box 7526 Guaynabo, PR 00971 809-720-8137	SOUTH TEXAS	Thomas Tanner, Sr. K5DG Rte 1, Box 45K La Feria, TX 78559-9716 210-797-3114
RHODE ISLAND	Michael Cardarelli, N1FKI 21 Tallman Ave. Cranston, RI 02910 401-941-7112	WEST TEXAS	Sherman L. McKean, W5MVJ 1000 Bonne Dr. Amarillo, TX 79108

	806-383-3197	EASTERN WASHINGTON	Jack Babbitt, WA5ZAY P O Box 951 Walla Walla, WA 99362 509-525-7003
UTAH	Michael Collett, K7DOU 650 E. Center St. Kaysville, UT 84037 801-544-1400	WESTERN WASHINGTON	Herb Posner, KC7FA 3313 S E Azalea Port Orchard, WA 98366 206-876-3485
VERMONT	Joseph Armstrong, KA1YLN 80 Clark St., Apt. 1 Brattleboro, VT 05301-3357 802-257-9170	WEST VIRGINIA	George Puzzuolo, K8QEW 3616 Morgan Drive Weirton, WV 26062 304-748-5707
VIRGINIA	Robert Lewis, N4SCK 5485 Braddock Ridge Dr. Centreville, VA 22020-1646 202-825-6665 (pager); 703-359-3200	WISCONSIN	John Leekley, WB9SMM W169 N8480 Sheridan Dr. Menomonee Falls, WI 53051 414-251-7056; 414-271-3744
VIRGIN ISLANDS	John Ellis, NP2B Gallows Bay Station P O Box 24492 Christiansted, VI 00824 809-773-9643	WYOMING	Francis R. McDonald, WB7K 4511 Bluebird Lane Laramie, WY 82070 307-745-8645
WASHINGTON			

## APPENDIX FIVE

# ARRL SECTION-WIDE EMERGENCY NETS



The following nets have been designated by ARRL Section Leadership officials as primary traffic outlets during section-wide emergencies. Nets with star (\*) indicate NTS affiliation.

NET NAME	FREQUENCY (kHz)	REGULAR MEETING UTC TIME (in winter)	MANAGER	
<b>ALABAMA</b>				
*Alabama Day Net	7243	M-Sn	1600	
*Alabama Section Net CW	3575	M-Sn	0100	
*Alabama Traffic Net Mike	3965	M-Sn	0030	
<b>CALIFORNIA</b>				
(Sacramento Valley)				
Northern California Net	3630	Dy	0300	
*Sacramento Valley Traffic Net	146.85 MHz	Dy	0500	
(Santa Barbara)				
*Southern California Net	223.92 -, 145.35 - & 147.975 -	Dy	0500	KK6GU
*Two Meter SSB/CW	144.230 USB	M	0430	KI6XG
<b>CONNECTICUT</b>				
*Connecticut Phone Net	3965	M-S	2300	KY1F
Connecticut Statewide Backup Net	145.68 MHz	when needed		NI1U
<b>FLORIDA</b>				
(Northern & Southern Florida sections)				
*Florida Amateur Sideband Traffic	3940	Dy	2300 & 0330	KE4ESV
*Florida Mid-day Traffic	7247.5	Dy	1700	WB4GCK
*Tropical Phone Traffic Net	3940	Dy	2100	WX4J

**KANSAS**

*Central States Traffic Net	7253.5	M-S	1830	AB5PA
*Kansas Section CW Net	3610	Dy	0000 & 0300	WB0ZNY
*Kansas Sideband Net	3920	Dy	0030	W0NBT

**MAINE**

*Maine Public Service Net	3940	Sn	1400	KA1LPW
*Pine Tree Net	3596	Dy	0000	NX1A
*Sea Gull Net	3940	M-S	2200	K1GUP

**NEVADA**

Nevada State RACES Net	3996.5	Th	0300	KI7DI
------------------------	--------	----	------	-------

**NEW YORK**

(New York City-Long Island)

*Big Apple VHF Traffic Net	146.43/ 147.43 MHz	Dy	0100	KB2KLH
----------------------------	--------------------	----	------	--------

(Western New York)

*Central New York Traffic Net (CNYTN)	147.30 + MHz & 147.00 -	SnTWFS M-Th	0215 0215	WA2PUU
---------------------------------------	----------------------------	----------------	--------------	--------

*New York Phone Net (NYP)	3925/7230	Dy	1800	N2LTC
---------------------------	-----------	----	------	-------

*New York Public Operations Net (NYPON)	3913/3925	Dy	2200	K2LYE
---	-----------	----	------	-------

*New York State CW Net (NYS)	3677/7040	Dy	00/03/1500	W12G/ W2YGW/ KA2GJV
------------------------------	-----------	----	------------	------------------------

New York State RACES Net (NYSR)	3530/7102	Sn	1430	W2MTA
---------------------------------	-----------	----	------	-------

New York State RACES Net (NYSR)	3993/7245	Sn	1400	N2AGO
---------------------------------	-----------	----	------	-------

*Oneida Co Traffic & Emergency Net	146.94 - MHz & 146.88 -	Dy Dy	2330 0230	N2SAA
------------------------------------	----------------------------	----------	--------------	-------

*Southern Tier Amateur Radio Net	146.73 -	Dy	2330	K2NCB
----------------------------------	----------	----	------	-------

*Western District Net (WDN)	146.64 -	Dy	0230/16/2330	WB2DYJ/ AF2K & ND2S
-----------------------------	----------	----	--------------	------------------------

Western New York Section Coordination	3995/7155	when needed		W2MTA
<b>OHIO</b>				
*Buckeye Net	3577	Dy	2345	WD8KFN
Ohio Section ARES Net	3875	Sn	2000	WD8MPV
*Ohio Single Sideband Net	3972.5	Dy	1530/2115 & 2345	WA8HED
<b>OKLAHOMA</b>				
*Oklahoma Phone Emergency Net	3900	Sn	1400	W5ZTN
<b>PENNSYLVANIA</b>				
*Eastern Pennsylvania CW Net	3610	Dy	0000	W3DP
*EPA Emergency Phone/Traffic Net	3917	Dy	2300	WA3HED
<b>SOUTH CAROLINA</b>				
ARES/RACES Emergency Net	3993.5	1,3 M	2300	K8AFP
*South Carolina SSB Net	3915	Dy	0000	WA4SJS
<b>SOUTH DAKOTA</b>				
South Dakota CW Net	3650	T-S	0100	K0ERM
South Dakota NEO Evening Net	3870	Dy	0000	K0ZBJ
<b>TEXAS</b>				
(North Texas and South Texas sections)				
*Daytime Texas Traffic Net	7273	M-S	1430	K5UPN
*North Texas ARES	3873	during emergencies		K5UPN
*Texas CW Net	3643	Dy	0100 & 0400	KS5V
*Texas Traffic Net	3873	Dy	0000	ND5C

**WASHINGTON**

*Washington State Emergency Net	3987	M & S	0200 & 1700	KC7FA
---------------------------------	------	-------	-------------	-------

**WEST VIRGINIA**

DAREN	145.69 - packet	W	0200	KA8LLM
Multi County ARES/RACES	146.685 - MHz	W	0230	W8SP
WVAR ARES/RACES	147.27 +	Sn	0230	K8KVD
*West Virginia Early Net	3567	Dy	0000	W8IMX
*West Virginia Phone Net	3865	Dy	2300	N8UGK
*West Virginia Mid-day Net	7235	Dy	1645	A18I

**WYOMING**

Wyoming ARES/RACES	3923 (7260 alternate)	Sn	1600	WB7K
HERCULES Voice Link Network (statewide)		M	0200	

**APPENDIX SIX****WIDE-AREA DISASTER RELIEF NETS**

NET	INFO
Hurricane Watch Net	14.325 MHz  Jerry Herman, N3BDW, Net Manager
UN Radio Readiness Group	14.268 MHz  David Rosen, K2GM, Net Manager
International Assistance and Traffic Net	14.303 MHz  Geri Sweeney, N4GHI, Net Manager

## APPENDIX SEVEN

## MUTUAL ASSISTANCE TEAM (ARESMT) CONCEPT

The ARESMAT concept recognizes that a neighboring section's ARES resources can be quickly overwhelmed in a large-scale disaster. ARES members in the affected areas may be preoccupied with mitigation of their own personal situations and therefore not be able to respond in local ARES operations. Accordingly, communications support must come from ARES personnel outside the affected areas. This is when help may be requested from neighboring sections' ARESMAT teams. The following is a checklist of functions for ARESMAT leaders.

#### **Pre-Departure Functions**

- Notification of activation/assignment
- Credentials issued
- General and technical briefing
- Review host SEC's invitation
- Transportation
- Accommodations
- Expected length of deployment reviewed

#### **In-Travel Functions**

- Review situation status, and sitreps
- Review job assignments
- Checklists
- Affected area profile
- Mission disaster relief plan
- Maps

- Technical documents
- Contact lists
- Tactical operation procedures

#### **Arrival Functions**

- Check in with host ARES officials
- Obtain information:
  - Frequencies in use
  - Current actions
  - Available personnel
  - Communication and computer equipment
  - Support facilities
  - Host's ARES plan
- Establish initial intra-team communication net
- Establish HF or VHF channel back to the home section for morale traffic



### **In-situ Functions**

- Initial assessment
- Monitor host ARES officials' communications
- Reduce duplication of effort
- Proper safety practices
- Daily critique of effectiveness

### **Pre-Demobilization and Demobilization Functions**

- Extraction procedure negotiated
- Demobilization plan in effect
- Team critique begun

### **ARESMAT Member Qualifications**

- High performance standards
- Qualifications
- Experience
- Team player
- Strong personal desire
- Strong interpersonal communication skills
- Emergency management knowledge
- Respected by officials and peers
- Available with consent of employer
- Physically fit

### **ARESMAT Concept Summary**

It should be noted that there is a fine balance of authority over a deployed ARESMAT. The in-disaster SEC (or delegated authority) should be able to make decisions as to use and deployment of an incoming team. Therefore, an incoming team should be prepared to submit themselves to such authority; this is evidenced by the fact that any team, internal or external, has only a limited view of the overall operation. The supervising authorities will naturally have a better overview of the whole situation.

In turn, however, the in-disaster authority should be discouraged from abusing the resources of incoming teams. Should a team no longer be required, or a situation de-escalate, the team should be released at the earliest possible time, so that they may return home to their own lives.

The ARESMAT tool should be one of "last resort--better than nothing." Whenever possible, amateurs from the affected section should be used for support. It is a lot to ask of a volunteer to travel far from home, family and job for extended periods of arduous and potentially dangerous work.

## **APPENDIX EIGHT**

## THE FEDERAL RESPONSE PLAN (FRP)

When disaster threatens a community -- a flood, an earthquake, a chemical spill -- local responders, government agencies and private organizations take action. Their goal: to save lives and help people cope with the chaos. And most of the time, with the help of the State, they have the skills and equipment to do the job. But sometimes the destruction goes beyond local and State capabilities. That's when Federal help is needed as well.

Typically, the Federal role is financial. But when State and local governments are overwhelmed by a catastrophic disaster, the Federal government is called in at once to mobilize resources from any number of Federal agencies, and sometimes to perform the response functions normally carried out by State and local governments. This is when the government implements the *Federal Response Plan* (FRP).

### **Concept**

The concept of the FRP is simple: In a catastrophic disaster, the Federal government provides State and local governments with personnel, technical expertise, equipment and other resources, and assumes an active role in managing the response.

Resources are provided by one or more of 26 Federal departments and agencies and the American Red Cross. Resources are grouped into 12 *Emergency Support Functions* (ESFs), including transportation, fire fighting, mass care, health and medical services, public works, urban search and rescue, and communications. Each ESF is headed by a *Primary Agency*. Other agencies provide support as necessary. Each agency responds within its own authorities.

Federal assistance is coordinated by the *Federal Coordinating Officer* (FCO), appointed by the President, and the *Emergency Response Team* (ERT). They work from a *Disaster Field Office* (DFO) near the disaster scene.

### **A Streamlined Process**

National emergency personnel, supplies and equipment are pre-positioned. An *Emergency Response Team -- Advanced Element* (ERT-A) is dispatched to the potential disaster area, ready to: Establish communications, help the State assess damages and identify needs, direct response activities, or handle State requests for assistance.

Amateur Radio is mentioned in three places in the FRP:

**ESF 2: Communications.** Under Resource Requirements, assets critical for the initial 12 hours, support for field activities, the plan refers to Amateur Radio networks/systems providing daily and emergency public service communications during emergencies and major disasters. It further refers to the League's ARES and NTS programs, and recognition of RACES and MARS.

**ESF 6: Mass Care.** Under the DWI (Disaster Welfare Inquiry) System, communications support agencies identified will be tasked with transmitting information to the DWI Center. "In no instance will fatality lists be transmitted via Amateur Radio or the American Red Cross 47.42 MHz system."

**ESF 8: Health and Medical Services.** Under "communications," "Amateur Radio frequencies and networks and the United States Army Military Affiliate Radio System (MARS) will be utilized to the extent necessary to help meet the communications requirements."

## **APPENDIX NINE**

# NATIONAL DISASTER MEDICAL SYSTEM

The National Disaster Medical System is a federally-coordinated initiative to augment the nation's emergency medical response capability. The overall purpose of NDMS is to establish a single national medical response capability for:

- Assisting state and local authorities in dealing with the medical and health effects of major peacetime disasters; and
- Providing support to the military and VA medical systems in caring for casualties evacuated back to the US from overseas armed conflicts.

NDMS has three major components: (1) Disaster Medical Assistance Teams (DMATs) and Clearing-Staging Units (CSUs) with necessary supplies and equipment which will be dispatched to a disaster site within the United States from the country's major metropolitan areas. DMATs/CSUs may also provide NDMS patient reception services at their home locations; (2) An evacuation capability for movement of patients from a disaster area to locations where definitive medical care can be provided; and (3) A voluntary hospital network which will provide definitive care.

*What is a Disaster Medical Assistance Team?*

A Disaster Medical Assistance Team (DMAT) is composed of about 35 volunteers which include physicians, nurses, technical staff and other health professionals as well as support staff. Team members will be trained to respond to a disaster as an organized group.

*How will patients be evacuated, received and transported to the participating NDMS hospitals?*

At the disaster site, patients will be stabilized by a DMAT and/or CSU for transport. In most cases, patients will be evacuated by air. At the airport of the NDMS reception area, patients will be met by a local DMAT which will sort, assess, and match those patients to participating hospitals.

*What is an NDMS Federal Coordinating Center?*

Currently, there are 107 metropolitan areas that serve as potential hosts to NDMS patients. For each NDMS area, there is a Coordinating Center, which is a Federal hospital. The Coordinating Center has three major functions: Recruit and maintain local non-Federal hospital participation in the NDMS; before a disaster, assist sponsors of DMATs and CSUs, participating hospitals and other local authorities in developing patient reception, transportation, and communication plans; and during System activation, coordinate the reception and distribution of patients coming into the area.

### **Amateur Radio Communication Support Functions**

*DMAT Support:* ARES members from the DMAT's home base are appointed as full members to the DMAT. They would be trained and be prepared to travel with the DMAT to the disaster area. The section ARES organization and the DMAT cooperatively develop a plan for broad-based support in the event that the team is deployed locally for an intra-state disaster.

All ARES members in general could be trained to meet the needs of DMAT teams in a disaster area under the direction of the DMAT member-hams. This is because ARES members located just outside of the disaster area could be called in to provide communications support as hams living in the disaster area would be preoccupied with personal situations and unable to assist.

*FCC Support:* ARES organizations need to develop a plan for supporting each of the 74 Federal Coordinating Centers (FCC). ARES members would supplement existing communications resources among the airport reception/triage sites, ambulances, hospitals and the FCC's headquarters. This would be implemented through local agreements between ARES and the FCCs.

## APPENDIX TEN

### WILDERNESS PROTOCOL

The Wilderness protocol (see page 101, August 1995 QST) calls for wilderness hams to announce their presence on, and to monitor, the national calling frequencies for five minutes beginning at the top of the hour, every three hours from 7 AM to 7 PM while in the back country. A ham in a remote location may be able to relay emergency information through another wilderness ham who has better access to a repeater. Calling Frequencies: 52.525, 146.52, 223.50, 446.00, 1294.50 MHz.

Name: \_\_\_\_\_ Call: \_\_\_\_\_ Date: \_\_\_\_\_

## ARES REGISTRATION FORM

Street: \_\_\_\_\_ City: \_\_\_\_\_ State: \_\_\_\_\_ Zip: \_\_\_\_\_

Bus. phone: \_\_\_\_\_ Home phone: \_\_\_\_\_ E-mail: \_\_\_\_\_

License Class: \_\_\_\_\_

Check bands/modes you can operate:

	HF	6-meters	2-meters	222 MHz	440 MHz	1.2 GHz
CW						
FM						
DATA						
SSB						
MOBILE						
PACKET						

Can your home station be operated without commercial power? Yes \_\_\_ No \_\_\_

If yes, what bands? \_\_\_\_\_

Signature: \_\_\_\_\_ Date: \_\_\_\_\_





## INCIDENT REPORT FORM

Please fill out this form and send a copy to your Emergency Coordinator and to ARRL Headquarters.

Nature of emergency/disaster:

---

---

Dates of activity: \_\_\_\_\_ Places or areas involved: \_\_\_\_\_

Nets and/or frequencies used:

---

Number of participating amateurs: \_\_\_\_\_ Number of messages handled: \_\_\_\_\_

Agencies supported: \_\_\_\_\_

ARES leadership officials managing deployment:

---

Your name/call: \_\_\_\_\_ Signature: \_\_\_\_\_ Date: \_\_\_\_\_



## INCIDENT REPORT FORM

Please fill out this form and send a copy to your Emergency Coordinator and to ARRL Headquarters.

Nature of emergency/disaster:

---

---

Dates of activity: \_\_\_\_\_ Places or areas involved: \_\_\_\_\_

Nets and/or frequencies used:

---

Number of participating amateurs: \_\_\_\_\_ Number of messages handled: \_\_\_\_\_

Agencies supported: \_\_\_\_\_

ARES leadership officials managing deployment:

---

Your name/call: \_\_\_\_\_ Signature: \_\_\_\_\_ Date: \_\_\_\_\_



## INCIDENT REPORT FORM

Please fill out this form and send a copy to your Emergency Coordinator and to ARRL Headquarters.

Nature of emergency/disaster:

---

---

Dates of activity: \_\_\_\_\_ Places or areas involved: \_\_\_\_\_

Nets and/or frequencies used:

---

Number of participating amateurs: \_\_\_\_\_ Number of messages handled: \_\_\_\_\_

Agencies supported: \_\_\_\_\_

ARES leadership officials managing deployment:

---

Your name/call: \_\_\_\_\_ Signature: \_\_\_\_\_ Date: \_\_\_\_\_



## INCIDENT REPORT FORM

Please fill out this form and send a copy to your Emergency Coordinator and to ARRL Headquarters.

Nature of emergency/disaster:

---

---

Dates of activity: \_\_\_\_\_ Places or areas involved: \_\_\_\_\_

Nets and/or frequencies used:

---

Number of participating amateurs: \_\_\_\_\_ Number of messages handled: \_\_\_\_\_

Agencies supported: \_\_\_\_\_

ARES leadership officials managing deployment:

---

Your name/call: \_\_\_\_\_ Signature: \_\_\_\_\_ Date: \_\_\_\_\_



# INCIDENT LOG SHEET

Date/Time	Event	Message From	Message To	Assigned Net Frequency	Assigned By



## INCIDENT LOG SHEET

Date/Time	Event	Message From	Message To	Assigned Net Frequency	Assigned By









# INCIDENT LOG SHEET

Date/Time	Event	Message From	Message To	Assigned Net Frequency	Assigned By



# INCIDENT LOG SHEET

Date/Time	Event	Message From	Message To	Assigned Net Frequency	Assigned By



# INCIDENT LOG SHEET

Date/Time	Event	Message From	MessageTo	Assigned Net Frequency	Assigned By





## INCIDENT LOG SHEET

Date/Time	Event	Message From	MessageTo	Assigned Net Frequency	Assigned By



## INCIDENT LOG SHEET

Date/Time	Event	Message From	Message To	Assigned Net Frequency	Assigned By

## NOTES

---

---

---

---

---

---

---

---

---

---

---

**FOR MORE INFORMATION**

CONTACT YOUR EMERGENCY COORDINATOR,

OR

PUBLIC SERVICE BRANCH  
FIELD SERVICES DEPARTMENT  
AMERICAN RADIO RELAY LEAGUE  
225 MAIN STREET  
NEWINGTON, CT 06111  
(860) 594-0261  
rpalm@arrl.org



